



Coimisiún na Scrúduithe Stáit
State Examinations Commission

Leaving Certificate Examination, 2021

Design & Communication Graphics

Ordinary Level

Sections B and C (120 marks)

Thursday, 24 June

Morning, 9:30 - 12:30

This examination is divided into three sections:

SECTION A	(Core - Short Questions)
SECTION B	(Core - Long Questions)
SECTION C	(Applied Graphics - Long Questions)

- SECTION A**
- Four questions are presented.
 - Answer **any three** on the accompanying A3 examination paper.
 - All questions in Section A carry **20 marks** each.

- SECTION B**
- Eight questions are presented.
- and**
- Answer **any two** on drawing paper.
- SECTION C**
- All questions in Section B and Section C carry **60 marks** each.

General Instructions:

- *Construction lines must be shown on all solutions.*
- *The graphics presented are not necessarily drawn to scale and must not be used for scaling purposes.*
- *Write the question number distinctly on the answer paper in Sections B and C.*
- *Work on one side of the drawing paper only.*
- *All dimensions are given in metres or millimetres.*
- *Write your Examination number in the box provided on section A and on all other sheets used.*

SECTION B - Core

Answer **any two** questions from the eight questions presented in **Section B** and **Section C** on drawing paper.

B-1. The 3D graphic on the right shows a dog kennel with the door in the open position.

Fig. B-1 below shows an isometric view of a similar kennel.

- (a) Draw the elevation of the kennel looking in the direction of the arrow and project the plan.
- (b) Draw the plan and elevation of the door in the open position as shown.
- (c) Draw the auxiliary elevation of the *kennel*, projected from the plan, which will include the true shape of face **A** of the door.



Scale 1:1

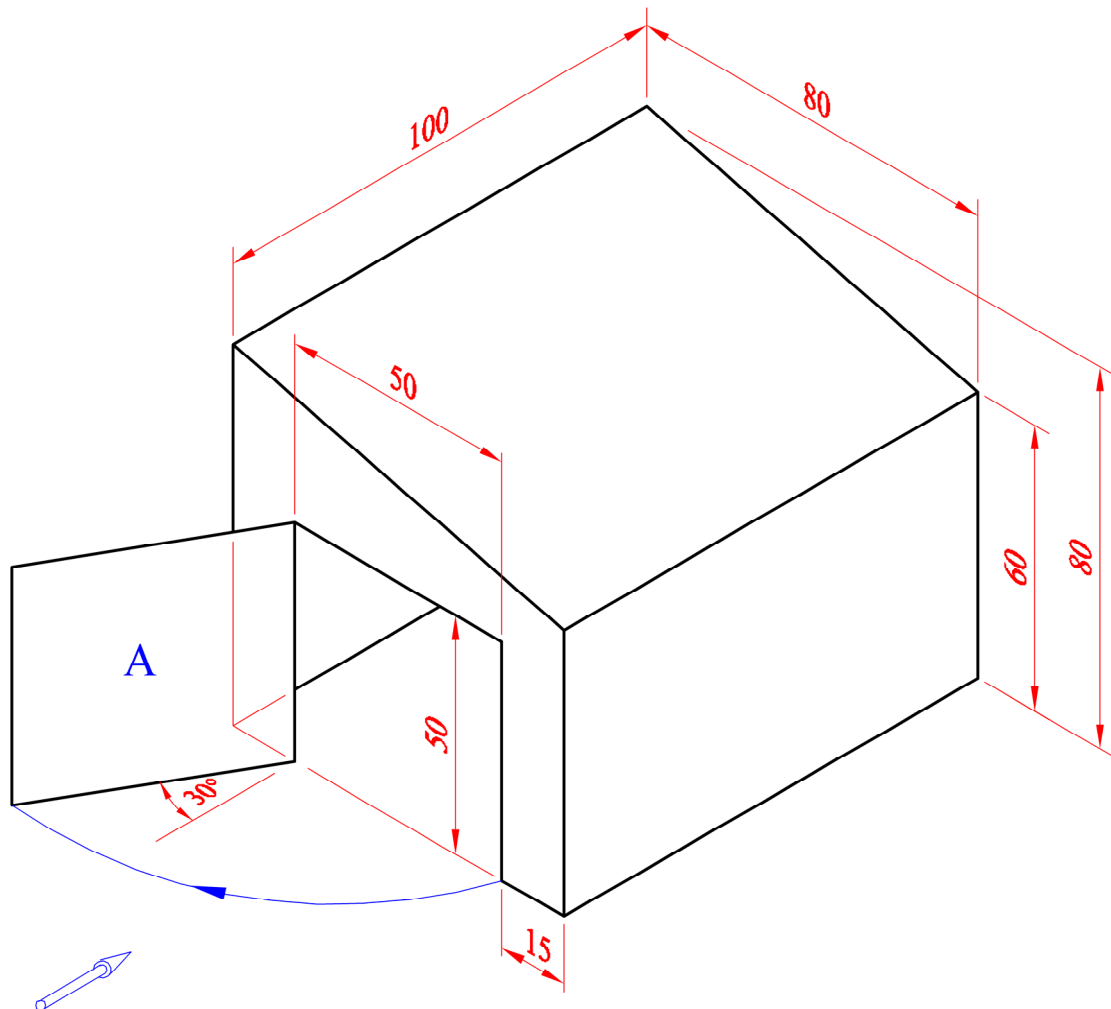

Fig. B-1

B-2. The image on the right shows a lifebuoy and its box.

Fig. B-2 below shows the axonometric axes and an incomplete isometric projection of a similar box. A 3D graphic is also given.

The elevation and plan of the box are also shown in their required positions.

- (a) Draw the given equilateral triangle **abc** and the axonometric axes **X, Y, and Z**.
- (b) Draw the elevation and plan positioned as shown.
- (c) Draw the axonometric projection of the rectangular outline of the lifebuoy box.
- (d) Complete the axonometric projection of the lifebuoy box including the semi-circular top.



Scale 1:1

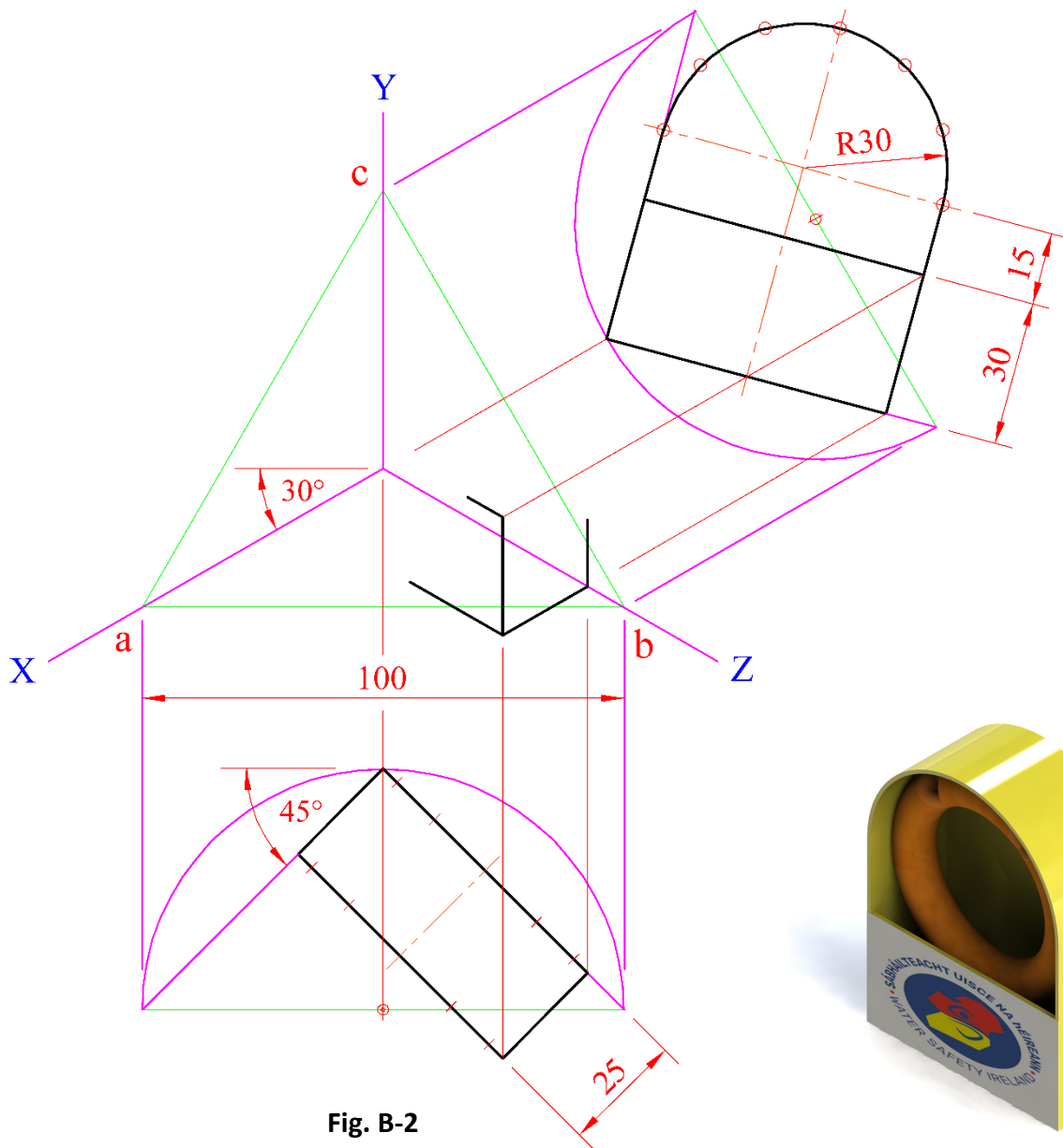
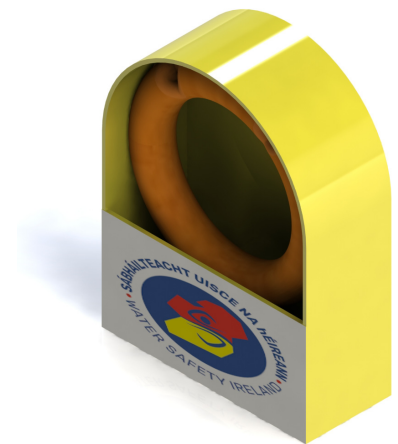

Fig. B-2



SECTION C - Applied Graphics

Answer **any two** questions from the eight questions presented in **Section B** and **Section C** on drawing paper.

Geologic Geometry

C-1. The accompanying map, located on the back page of Section A, shows ground contours at five metre vertical intervals.

- (a) On the map supplied, draw a vertical section (profile) on the line **AB**.
- (b) Points **C**, **D** and **E** are outcrop points on the surface of a stratum of ore.
Draw the plan and elevation of the triangle **CDE**.



- (c) Determine the strike and dip of the stratum.

Scale 1:1000

Structural Forms

C-2. The image on the right shows a climbing frame from a children's playground. It contains a series of hyperbolic paraboloid surfaces.



Fig. C-2 below shows the projections of a similar hyperbolic paraboloid surface.

- (a) Draw the elevation and plan of the given hyperbolic paraboloid surface.
- (b) Project an end view of the surface.

Scale 1:1

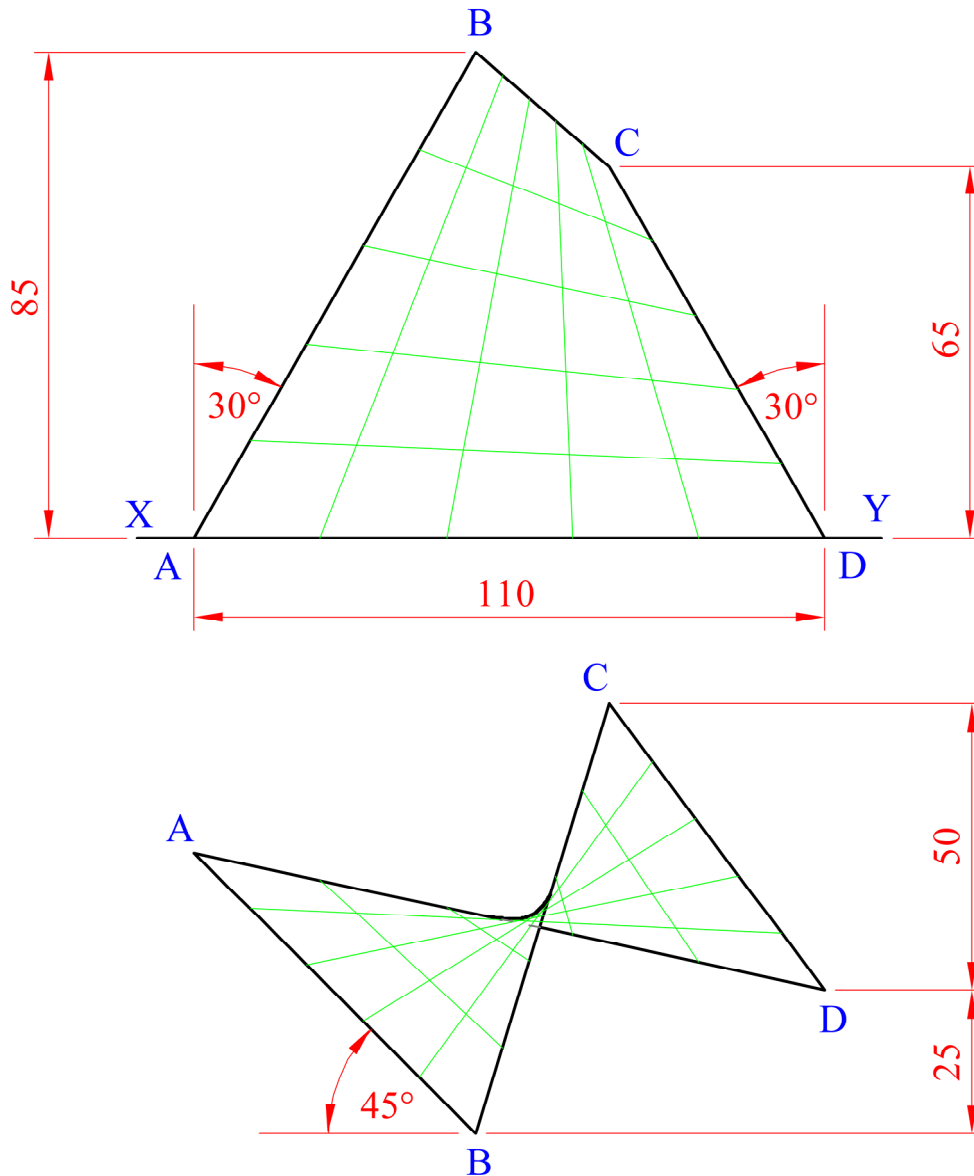

Fig. C-2

Surface Geometry

C-3. The image on the right shows a 'Magnum' ice cream and a wrapper.

The projections of a similar wrapper are shown in Fig. C-3 below.



- (a) Draw the given elevation and plan of the wrapper. Show clearly how the points of contact are located in the elevation.
- (b) Project an end view of the wrapper.
- (c) Draw a one-piece surface development of the wrapper.

Scale 1:1

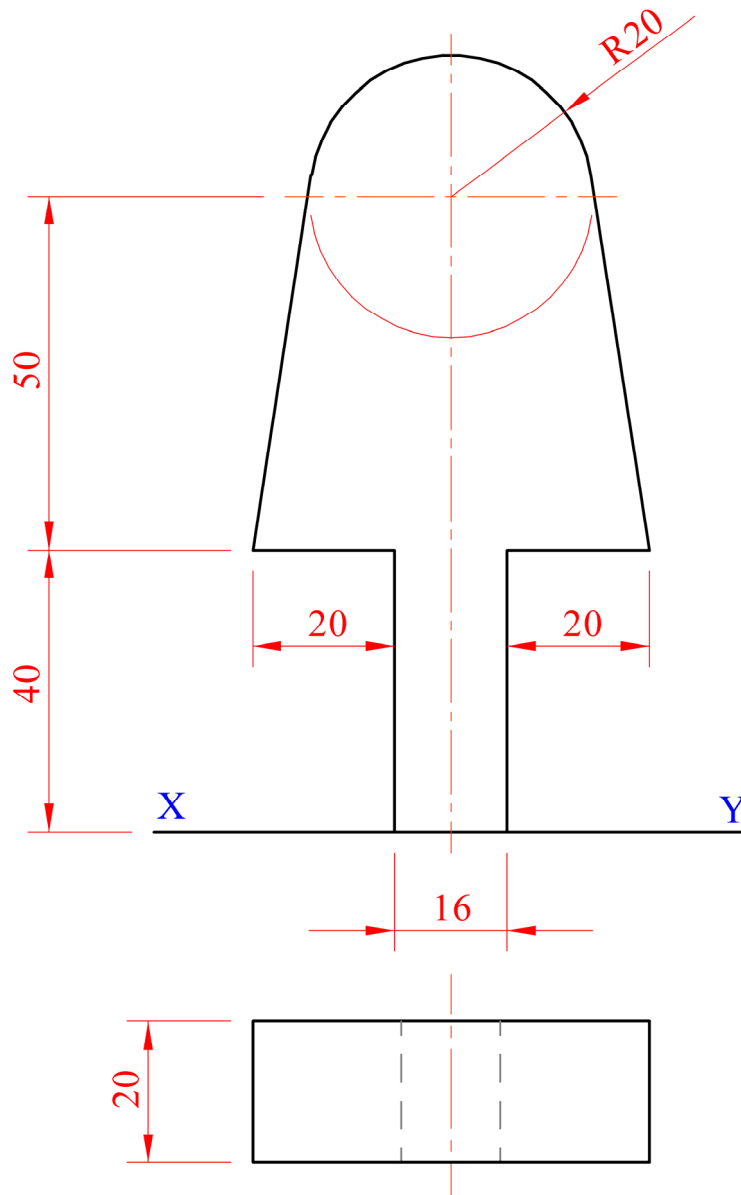

Fig. C-3

Dynamic Mechanisms

C-4. A cam, as shown, is often used as part of a sewing machine.

- (a) Draw the displacement diagram for a cam which imparts the following motion to an inline knife edge follower:



- 0° to 90° Rise 60mm with uniform velocity
- 90° to 180° Dwell
- 180° to 360° Fall 60mm with uniform acceleration and retardation.

(In the displacement diagram, use a distance of 15mm to represent each 30° interval.)

Note: It is not necessary to draw the cam profile.

- (b) The image below shows an enlarged view of the sewing machine mechanism.

Fig. C-4(b) shows a line diagram of this mechanism.

Crank **OA** and rod **AC** are pin jointed at **A**. Point **B** is located on the rigid rod **AC** as shown.

Crank **OA** rotates in a clockwise direction, about point **O**, for one revolution. Point **C** moves on the vertical axis as shown.

Plot the locus of point **B** for this movement.

Scale 1:1

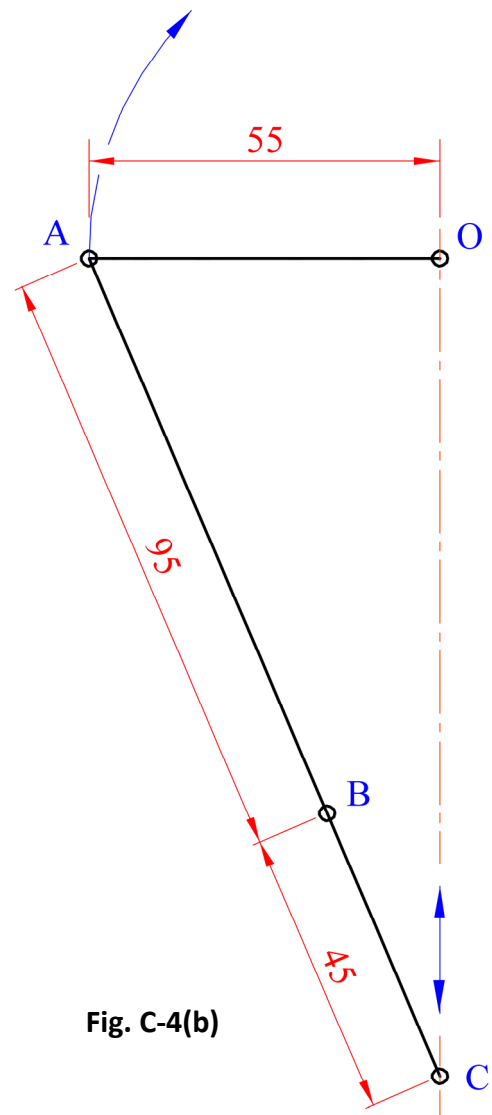

Fig. C-4(b)

Assemblies

C-5. Paint rollers similar to the one shown are used in home decoration. Details of the paint roller are given in Fig. C-5 below.

A parts list and a 3D graphic of the roller are also shown.

Draw the **sectional elevation A-A** of the assembled paint roller.

(Any omitted dimensions may be estimated.)

Scale 1:1

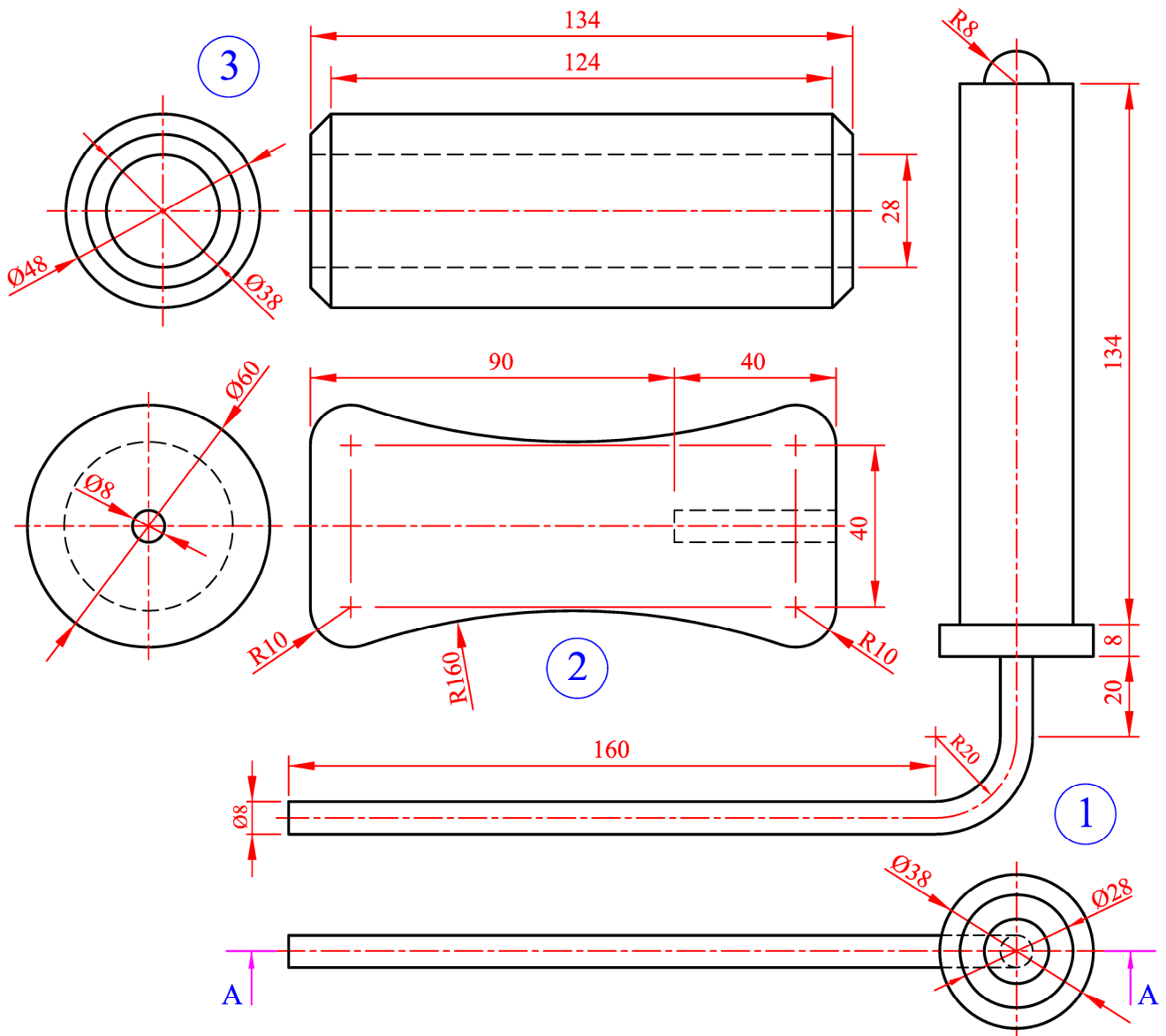

Fig. C-5

Part	Name	Qty.
1	Main Body	1
2	Handle	1
3	Roller	1

There is no examination material on this page

There is no examination material on this page

There is no examination material on this page

20

This Contour Map is part of Section C
and should only be used for the
answering of the Geologic Geometry
Option (Question C-1).

(Scale 1:1000)

