



**Coimisiún na Scrúduithe Stáit
State Examinations Commission**

JUNIOR CERTIFICATE EXAMINATION, 2011

**MATERIALS AND TECHNOLOGY
METALWORK**

Higher Level - 100 Marks

Tuesday, 21 June Afternoon 2:00 – 4:00

INSTRUCTIONS

1. Answer Question 1 - Sections A and B, and three other questions.
2. All answers must be written in ink on the answer book supplied. Diagrams should be drawn in pencil.
3. Squared paper is supplied for diagrams as required.
4. Please label and number carefully each question attempted.

SECTION A – 20 MARKS
COMPULSORY

Answer **any five** questions.

The diagram, Fig. 1, shows some of the main parts of a basic two-stroke engine.

Questions (a) to (d) relate to this diagram.

- (a) (i) Name **both** of the engine Ports ‘A’ and ‘B’ shown.
- (ii) Explain the purpose of **one** of the ports, ‘A’ or ‘B’.

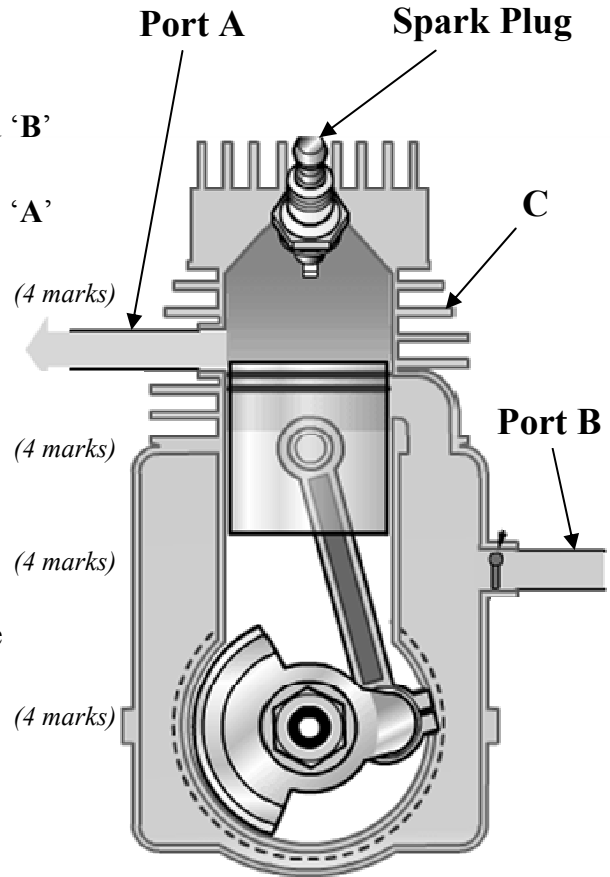

(4 marks)

(4 marks)

(4 marks)

(4 marks)

- (b) (i) Identify part ‘C’ of the engine.
- (ii) Explain the purpose of part ‘C’.

- (c) Describe the function of the Spark Plug.

- (d) Outline the operation of the engine during the downward stroke.

- (e) Briefly describe the contribution made to technology by **one** of the following people:

- (i) Bill Gates, or
- (ii) Alexander Graham Bell, or
- (iii) John P. Holland.

(4 marks)

Fig. 1

- (f) (i) Name **any two** alloy steels.
- (ii) State **one** common application for an alloy steel.

(4 marks)

- (g) (i) Identify **both** electronic components ‘D’ and ‘E’ shown in the electronic circuit.
- (ii) Draw, using the correct electronic symbols, a circuit diagram for the circuit shown.

(4 marks)

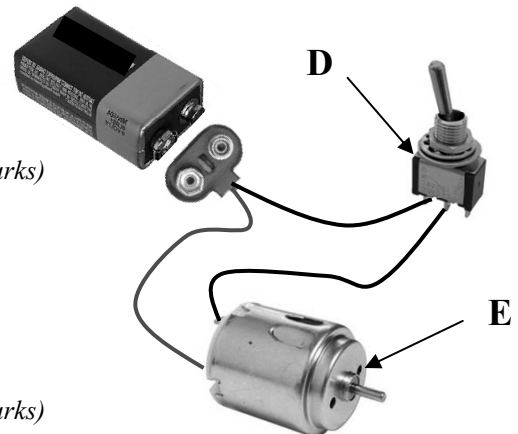

Electronic Circuit

**SECTION B – 20 MARKS
COMPULSORY**

Answer **any five** questions.

The drawings show the Frame, Sidecar Mudguard, Electronic Circuit and an assembly drawing of the 2011 Metalwork Higher Level Project, Model Motorcycle and Sidecar.

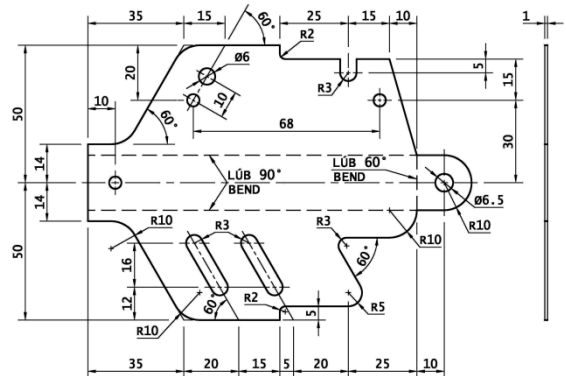

Frame

- (a) (i) Calculate the overall length and width of the Frame, before it is bent into shape.
 (ii) Identify **one** instrument used to measure and mark out the 60° angles on the Frame.
 (4 marks)

- (b) (i) List **any two** steps required to accurately shape the external profile of the Frame.
 (ii) Describe how the 6 mm slots are produced in the Frame.
 (4 marks)

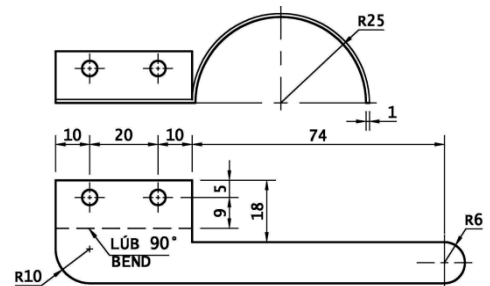

Sidecar Mudguard

- (c) Describe how the Sidecar Mudguard is bent to shape with particular reference to:
 (i) the 90° bend;
 (ii) the R 25 arc.
 (4 marks)

- (d) (i) Explain the purpose of the resistor connected to the LED in the Electronic Circuit.
 (ii) Suggest **any two** factors necessary to produce good quality soldered connections in the Electronic Circuit.
 (4 marks)

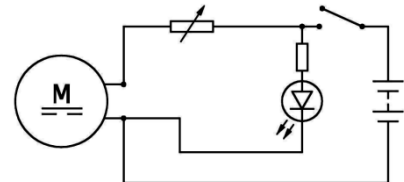

Electronic Circuit

- (e) Design, using a diagram, a front fork, windscreen and front wheel to be assembled as a unit on the model.
 (4 marks)

- (f) Design, using a diagram, an attachment for the Sidecar to protect the passenger from elements of the environment such as wind or rain.
 (4 marks)

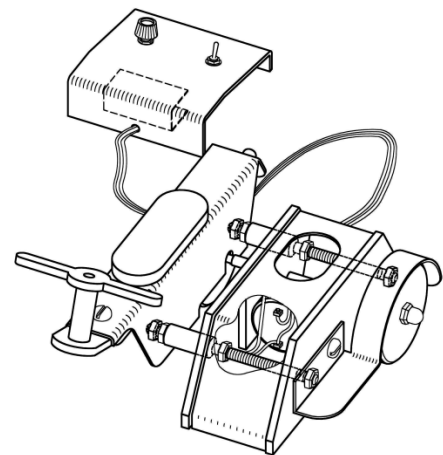

Motorcycle and Sidecar

A simple model of a design process is shown opposite.

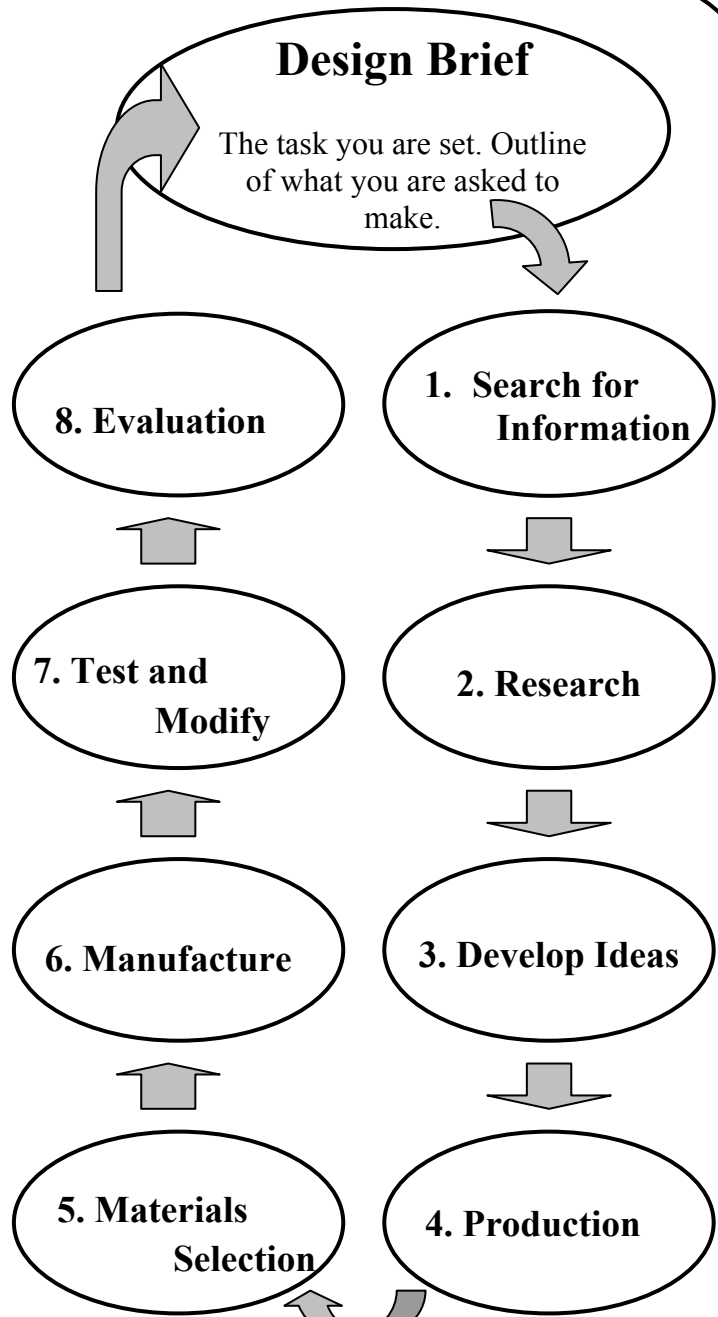

- (a) (i) List **any three** important points which should be considered at the 'Materials Selection' stage.
- (ii) Outline **any two** safety precautions to be taken at the 'Manufacture' stage. (6 marks)

A sitting room fireplace is shown.

- (b) (i) Draw, in proper proportion, an elevation of the shaded sections of the fireplace, looking in the direction of arrow 'A'.
- (ii) Design, using a diagram, a metal safety guard which may be placed in front of the fireplace. The guard must be capable of folding for storage.
- (iii) Design **one** decorative feature which may be applied to the safety guard.
- (iv) Suggest **one** suitable metal from which the safety guard may be manufactured and **one** suitable finish for the safety guard. (14 marks)

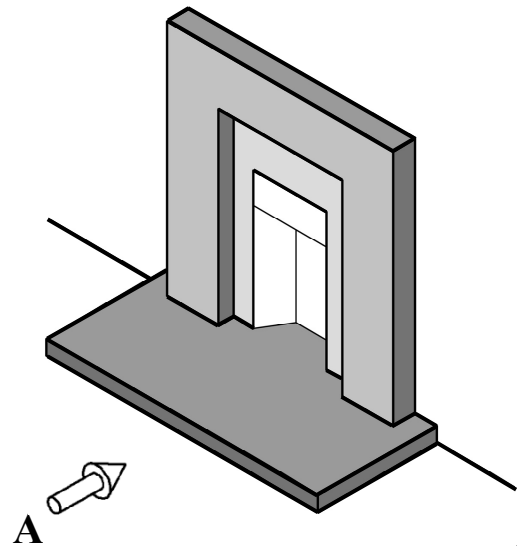

Question 3

20 Marks

- (a) (i) Outline how the positions of the Ø10 mm holes may be accurately located on the bracket as shown.
- (ii) List **any two** safety precautions to be taken when drilling the Ø10 mm holes.
- (iii) State **any two** reasons why drilling machines are designed to run at different speeds (RPM). (8 marks)

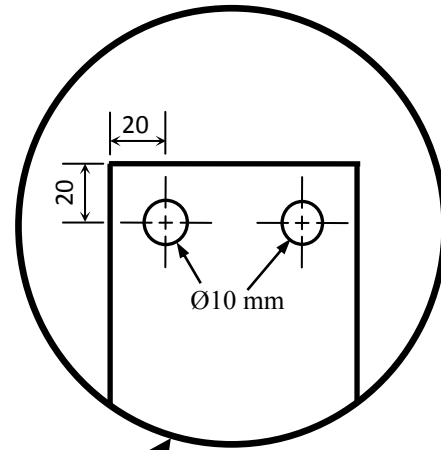

- (b) A 12 mm hole is to be drilled in a material which has a surface cutting speed of 72 m/min. Using the given formula calculate the speed in RPM. (Take π as 3)

$$N = \frac{S \times 1000}{\pi \times D} \quad (4 \text{ marks})$$

- (c) Select **any two** of the following and explain the difference between the terms:
- (i) Clearance Hole and Blind Hole;
- (ii) Taper Tap and Plug Tap;
- (iii) Snap Head Rivet and Pop Rivet. (8 marks)

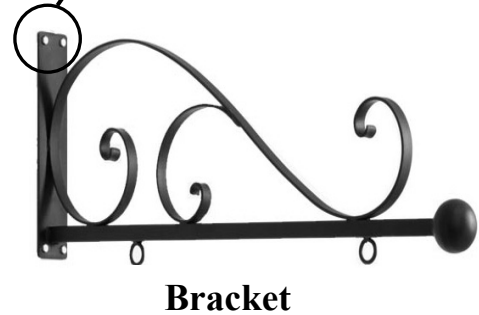

Question 4

20 Marks

- (a) (i) Name the type of furnace shown.
- (ii) List the materials in the charge.
- (iii) Describe how the furnace is charged.
- (iv) Explain, making reference to part 'A', how the charge is heated or melted.
- (v) Outline the function of part 'B'. (10 marks)

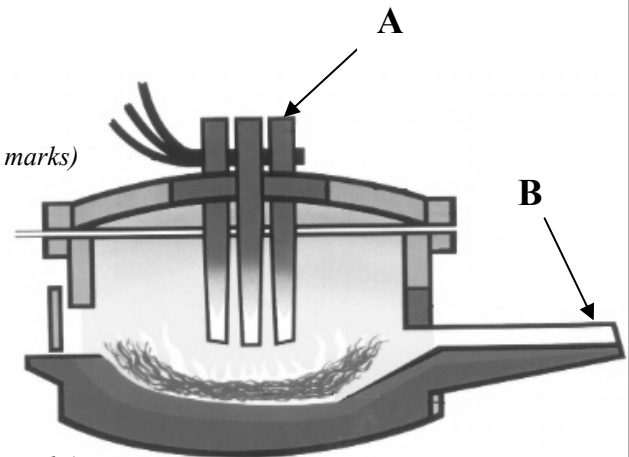

- (b) Define **any two** of the following material properties:

- (i) Toughness;
- (ii) Strength;
- (iii) Malleability;
- (iv) Brittleness. (4 marks)

- (c) (i) List the elements used to make **each** of the following alloys:

- Brass;
- Bronze.

- (ii) Identify **one** alloy used to manufacture the piston shown opposite. (6 marks)



Question 5

20 Marks

A motorbike is shown opposite.

- (a) (i) Name a suitable material for **each** motorbike part labelled.
- (ii) State **one** reason for the selection of **each** material.
- (iii) Suggest **one** advantage and **one** disadvantage of motorbikes as a mode of transport.
- (iv) Outline **any two** safety features of a motorbike.

(10 marks)

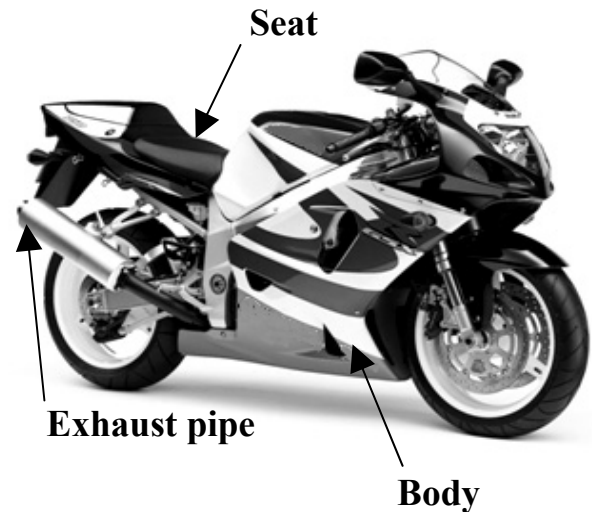

- (b) (i) Identify the drive mechanism shown.
- (ii) If the driver has 30 teeth and the driven has 10 teeth, what is the gear ratio?
- (iii) If the driver turns at 50 RPM, how fast does the driven turn in RPM?
- (iv) Suggest **one** method used to reduce noise or prevent wear of the mechanism.

(10 marks)



Drive Mechanism

Question 6

20 Marks

- (a) (i) Describe how the pendant shown may be shaped from 1 mm copper sheet.
- (ii) Explain, using a diagram, how the pendant may be finished by Mottling.
- (iii) Briefly describe **one** of the following decorative metal finishes:
- Enamelling;
 - Etching;
 - Repoussé.

(10 marks)

- (b) (i) Describe the heat treatment process of Hardening.
- (ii) Name **any two** other heat treatment processes.
- (iii) Outline **any two** reasons for the heat treatment of metals.
- (iv) Suggest **any two** safety precautions to be taken when heating metals.

(10 marks)

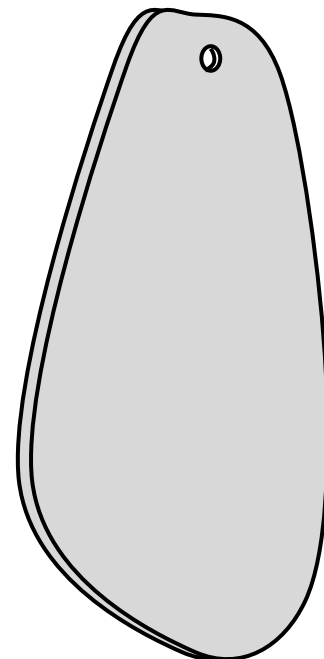

Pendant

Question 7

20 Marks

- (a) (i) Identify the type of lathe shown.
- (ii) Explain the purpose of **both** of the lathe parts 'A' and 'B' shown.
- (iii) Which polymer from the list below is the most suitable to make part 'B'? Explain **one** reason for its selection:
- Acrylic;
 - Polyurethane;
 - Nylon.

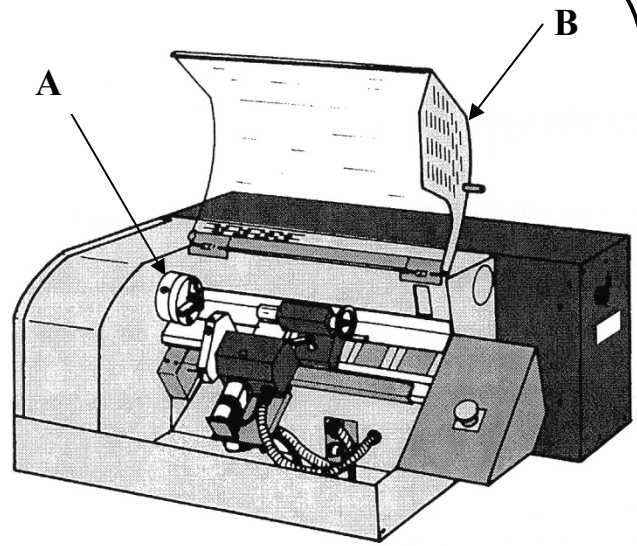

- (iv) Explain the main difference between Thermosetting and Thermoplastic polymers **and** state if the material selected to make part 'B' on the lathe shown is either Thermosetting or Thermoplastic.
- (v) Outline **one** environmental problem caused by the incorrect disposal of plastic materials.

(10 marks)

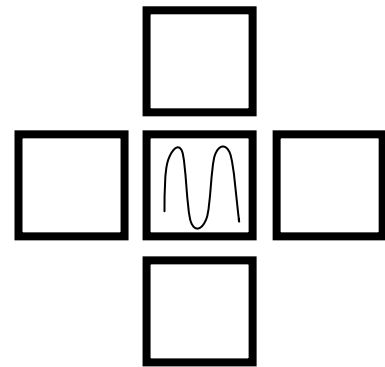

Jog Keys

- (b) (i) Redraw, in your answer book, the jog keys shown and label the correct directions -X, +X, -Z and +Z.
- (ii) Explain **any two** of the following terms:
- CPU;
 - G-codes;
 - Canned cycles;
 - CAD.

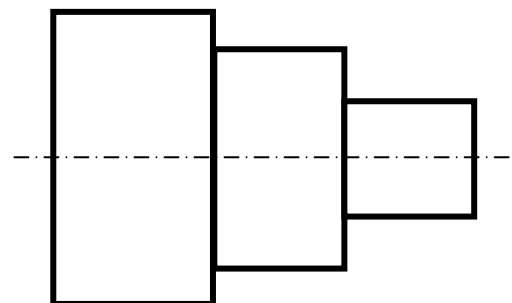

Lathe Component

(10 marks)

Blank Page